



Partial Discharge and Cross Interference Phenomena in a Three-phase Construction

Umar Khayam, Shinya Ohtsuka, Satoshi Matsumoto,
Masayuki Hikita

Kyushu Institute of Technology,
Department of Electrical and Electronic, and Computer Engineering,
1-1 Sensui-cho, Tobata-ku, Kitakyushu, 804-8550 Japan

Abstract: This paper deals with partial discharge measurement and partial discharge characteristics on a three-phase construction. A simplified model of three-phase gas insulated switchgear is used in the experiment to simulate three-phase electric field in three-phase equipment. A particle was adhered on the different positions on the conductor and on the tank to produce partial discharge. Partial discharge signals flowing on three phase conductors were measured simultaneously with three high frequency current transformers clamped on the three-phase lines through capacitive voltage divider. Partial discharge signals induced on the enclosure were measured with the current transformer and the detecting impedance. The circuit was calibrated and examined by injecting known charges from a pulse calibrator to some points in the circuit. The calibration results indicate that measuring partial discharge signals only at the enclosure or on one of the phases of three phase construction will result in the position dependent sensitivity for partial discharges. Experimental results show that partial discharge inception voltages of a particle adhered on different position differed depended on the particle position. Phase of partial discharge inception voltage also depended on the particle position. Experimental results show that partial discharge caused by a particle on one phase conductor was induced and detected on the other phase conductors. Polarity and magnitude of discharge current flowing on each phase depended on the particle position. Each particle at different position generated discharge current which flowed on each phase so that the magnitude ratios of the currents flowing on each phase were unique for each particle. These results were discussed with considering electric field characteristic in three-phase construction and coupling capacitance between three-phase conductors and between the conductors and the tank.

Index Terms : partial discharge, three-phase voltage, electric field, cross-interference

1. Introduction

DISCHARGE characteristics in single-phase equipments are a well-known and well-established art, however, those in three-phase equipment such as three-phase gas insulated switchgear (GIS) and three core belted power cable are far less understood. The investigation of partial discharge (PD) characteristics under three phase electric field on three-phase equipment is needed because some reasons. Firstly, there is a distinct difference in electric field characteristics between single-phase and three-phase construction. The electric field in single-phase equipment is linear, while one in three-phase equipment rotates and changes continuously [1-3]. It can be expected that the PD characteristics in three-phase equipment are different from ones in single phase equipment. Further, the particle movement inside the three-phase gas insulated system is influenced strongly by three-phase electric field [2,4]. Secondly, for the reason of its compactness and low cost, the application of three-phase equipment (three-phase in one tank), such as three-phase GIS and three-phase gas insulated bus (GIB), has been increasing [5].

*Corresponding Author: Umar Khayam, School of Electrical Engineering and Informatics, Institut Teknologi Bandung, Jl. Ganesha 10 Bandung INDONESIA, 40132 Telp./ Fax.: 62-22-2500995.
Email: umar@hv.ee.itb.ac.id*

Thirdly, application of single-phase testing technique to three-phase equipment gives some erroneous results [6,7]. Fourthly, three-phase equipment is energized by three-phase voltage on on-line PD monitoring of medium and high voltage equipment [3]. It differs from common practice for off-line test which is to energize only one phase.

Recently, the PD investigations on three phase equipment have been reported. The topics included rotating electric field in three-phase equipment [1-3] and its effects on PD characteristics [1,2] and particle movement on three-phase equipment [2,4], development of three-phase PD detection using single-phase test voltage [6,7], and development of PD measurement technique on three-phase equipment [8-16]. Fundamentals aspects of excitation and propagation of PD signal in three phase power cable have been reported, however the PD excitation were only explained with simulation [3]. PD characteristics, mainly explained from measurement on three-phase construction, are still not adequate.

From these viewpoints, PD characteristics from a particle in a three-phase construction under three-phase voltage are investigated. The measurement system is developed to observe discharge characteristics under three-phase voltage. PD from a artificial particle adhered on the conductors and on the tank were observed. In this paper, the PD occurrences and cross interference phenomena in three phase construction are reported.

2. Experimental setup

The measurement system was developed to investigate discharge characteristics under three-phase voltage. A simplified model of a three-phase GIS was used. It was composed of a tank model 150 mm in diameter, 300 mm in length, 2 mm in thickness, and three-phase conductors 25 mm in diameter. The electrode system was arranged to simulate three-phase electric field in three-phase equipment. The conductors were arranged in an isosceles triangle construction. The maximum voltage of three-phase transformer used for the experiment was 52 kV. The dimensions of the tank and the conductors were about one fifth of an actual 275 kV three-phase GIS. The layout and dimensions of the model are shown in Figure 1. The experimental setup is shown in Figure 2.

The experiments were conducted in laboratory air. Three-phase AC voltage was supplied from a three-phase 200 V/52 kV, 5 kVA corona free transformer through 20 k Ω limited resistor. PD signal flowing in each phase was measured by three current transformers with frequency band 10 kHz – 250 MHz, namely CT_R, CT_S, and CT_T. They were clamped on the line connecting the coupling capacitors and the capacitive dividers on R, S, and T phases, respectively. PD signal flowing from the tank to ground was detected by CT, namely CT_{TANK}, and 1 k Ω detecting impedance (DI). The detecting impedance is able to measure signal with frequency up to 300 MHz.

Applied voltage was measured with capacitive dividers consisting of 500 pF and 450 nF capacitances. PD signals and applied voltage were observed simultaneously with a four-channel oscilloscope.

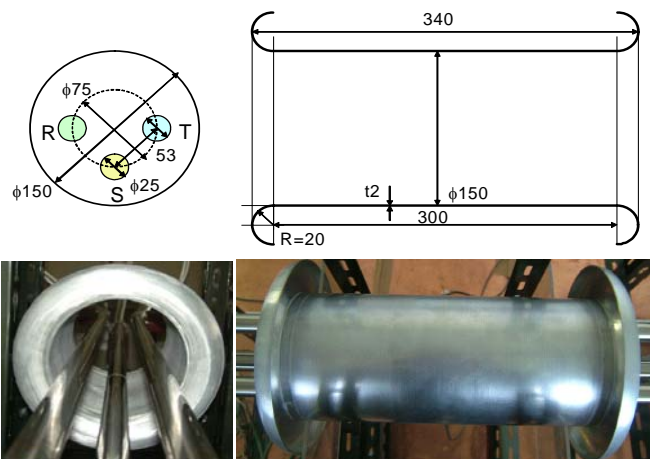

Figure 1. Layout of simplified model of three-phase GIS

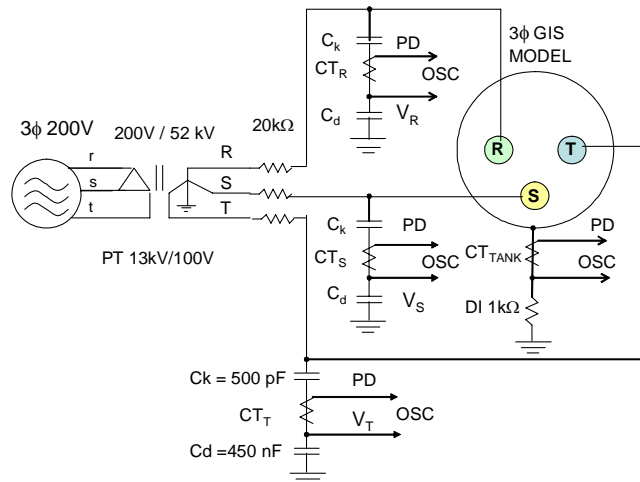

Figure 2. Equivalent circuit of experimental setup

3. Calibration and analysis of three-phase pd measurement system

The measurement system was calibrated to verify the relation between the reading of the PD measurement system (mV) and injected charge (pC) and to verify sensitivity of the measurement system. The calibration of PD measurement system was done by injecting positive and negative known charges from a pulse calibrator to some injecting points as follows: phase to phase (R-S, R-T, S-T) and phase to tank (R-Tank, S-Tank, T-Tank) respectively. The high frequency current was measured with the PD measurement system and observed with an oscilloscope.

The examples of calibration results are shown in Figures 3 and 4. Figure 3 shows the response of CT clamped on S phase (CT_S) when charges are injected to some different points. It appears that CT_S detected charges injected to S phase. In addition, it also detected charges injected to another points, such as R-T, R-tank, and T-tank. It means that charges injected to one phase were also induced to the other phases and to the enclosure. It appears that the response of charges injected to S phase is higher than that injected to the other points. It means that CT_S has high sensitivity for discharge occurring around S phase.

Figure 4 shows the response of CT clamped on the line connecting the tank and ground (CT_{TANK}) when charges are injected to some different points. It appears that the response of charges injected to the tank (phase-tank or tank-phase) is higher than those injected to the other points (phase-phase). It means that CT_{TANK} has high sensitivity for discharge occurring between the conductor and the tank.

The results indicate some guidance for PD measurement on three-phase construction as follows.

- PD occurring on one of three phase conductor induces charges to the other phases and the enclosure.
- Measuring PD current flowing in one of three-phase conductors is sensitive for discharges which occur around the conductor (between the conductor and the tank, and between the conductor and the other conductors), but less sensitive for discharges which occur between the other two conductors and between the other conductors and the tank (Figure 3).
- Measuring PD current flowing from the enclosure (tank) to ground is sensitive for discharges which occur between each conductor and the tank, but less sensitive for discharges which occur between the conductors (Figure 4).
- Measuring PD current only at the enclosure of three phase construction or only at one of the phases will result in position dependent sensitivity for PDs.

The calibration results indicate that PD measurement must be conducted on three phases simultaneously to obtain measurement results of PD occurring in entire region of three-phase construction with high sensitivity,.

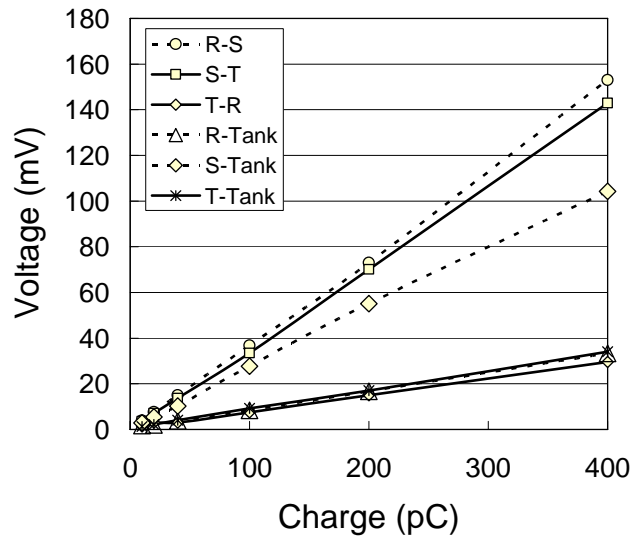

Figure 3. Calibration results of CT_S

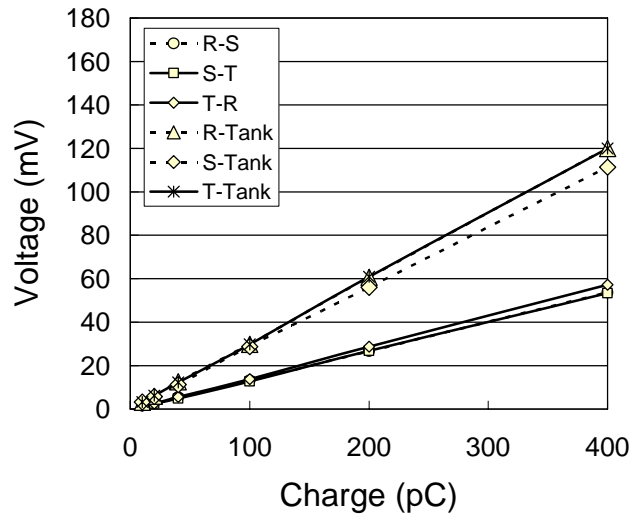

Figure 4. Calibration results of CT_{TANK}

4. Experimental results

4.1 The Dependence of PDIV on particle position

Partial discharge from a particle placed at different positions on HV conductor and the tank was measured. The particle positions and their notations are shown in Figure 5. The diameter of a particle is 0.1 mm. The radius of particle tip is 0.05 mm. The particle length is 5 mm. PDIV of these particles are shown in Figure 6. The results show that PDIV- is lower than PDIV+ for the particles on HV conductor and on the contrary for the particles on the tank. PDIVs of a particle adhered on different positions differed, depended on the particle position.

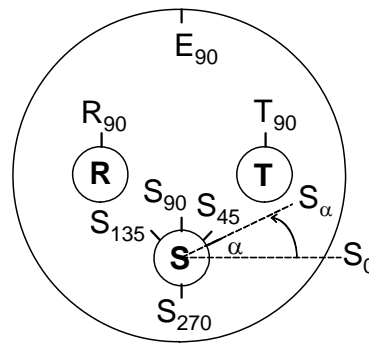

Figure 5. Artificial particle positions and notations

PDIV vary between 4 kV and 6 kV for a particle adhered on the different positions on the conductor and between 8 kV and 11 kV for a particle on the different positions on the tank. PDIV of a particle on the tank is higher than PDIV of a particle on the conductor. PDIV of a particle on the region between phases (R315, S90, and S135) is around 4 kV, lower than PDIV of a particle on the other places.

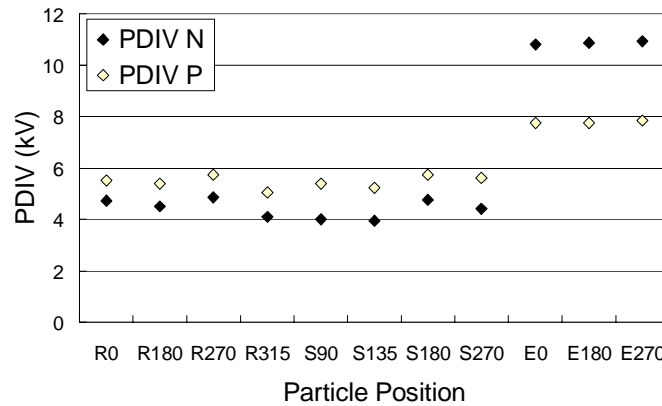

Figure 6. PDIV of particles on the conductor and on the tank

4.2 The Phase dependence of pd occurrence on particle position

Figure 7 until 9 show experimental results of PD occurrence at PD inception voltage (PDIV) from a particle on some different positions. Figure 7 and 8 show the examples of PD occurrences during two cycles of applied voltage at PDIV for a particle adhered on the conductor and a particle adhered on the tank respectively. It appears on Figure 7 that PDIV of S45 particle occurred when phase of S voltage θ_s is around 247° . On the other hand, PDIV of S270 occurred when $\theta_s = 270^\circ$. Then, it appears on Figure 8 that PDIV of particle on the tank E180 and E270 occurred at $\theta_s = 330^\circ$ and $\theta_s = 90^\circ$, respectively. The other experimental results are summarized on Figure 9. It appears that phases of PDIV depended on the particle position.

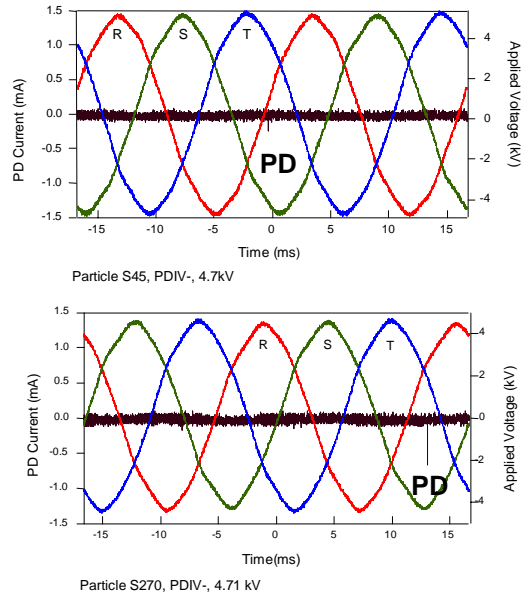

Figure 7. PD occurrences on 2 cycles of applied voltage at PDIV (particle on the conductor)

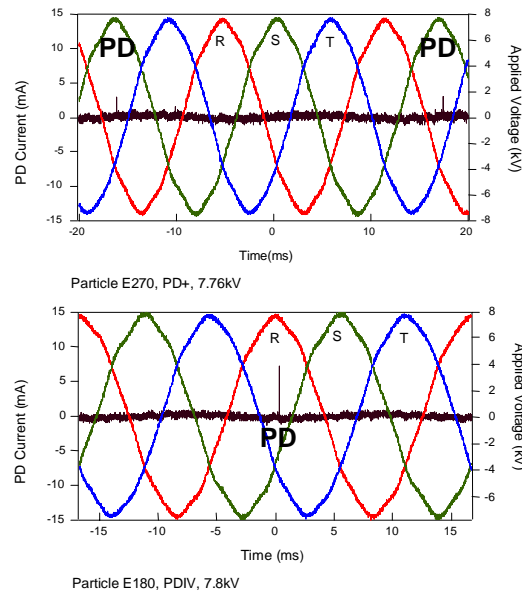

Figure 8. PD occurrences on 2 cycles of applied voltage at PDIV (particle on the tank)

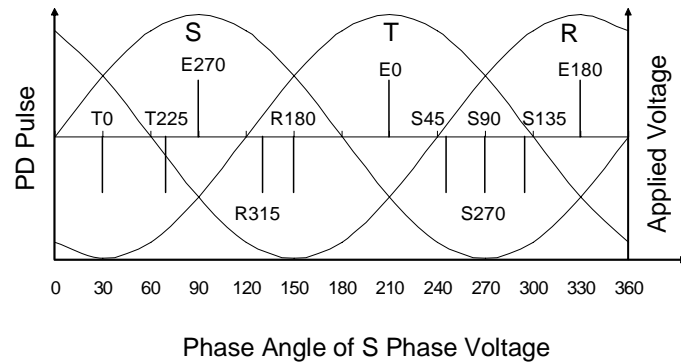

Figure 9. Resume of phase of applied voltage at PDIV for a particle on some different positions

4.3 Cross interference phenomena

Figure 10 shows waveform of discharge current flowing on each phase for S90 particle. PD currents measured by CT_R , CT_S , CT_T , and CT_{TANK} were 0.40mA, 0.88mA, 0.48mA, and 0.25mA, respectively. It appears that discharge caused by particle on S phase caused currents to flow on R, S, and T phases and to the enclosure. It means that the discharge occurring on one phase was induced and detected on the other phases. The charge was also induced to the tank.

For further analysis the magnitude of PD currents flowing on each phase measured by CT is classified. The magnitude of PD current flowing on each phase and the enclosure are normalized. Then, the maximum of normalized currents flowing on each phase, further is called as magnitude ratio (A), were determined. The magnitude ratio is classified as follows: low (L) for $A < 0.4$; medium (M) for $0.4 \leq A < 0.7$; and high (H) for $A \geq 0.7$. Based on the classification, PD pulses from S90 particle as shown in Figure 10 result in low and negative current detected by CT_{TANK} , medium and negative current detected by CT_R and CT_T , high and positive current measured by CT_S . Example of the other results is summarized in Table 1.

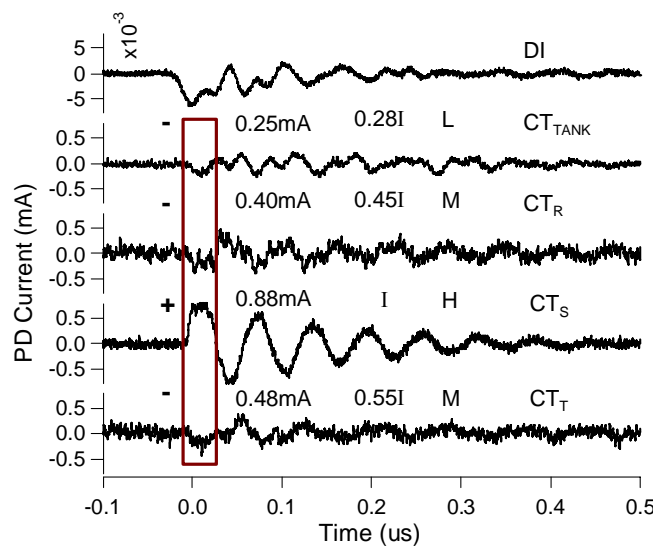

Figure 10. PD Current waveform measured for S90 particle

Table 1 Polarity and magnitude level of discharge currents measured for particles on S conductor

Particle Position	PD Polarity	Discharge Current			
		CT _{TANK}	CT _R	CT _S	CT _T
S90	PD-	L-	M-	H+	M-
S90	PD+	L+	M+	H-	M+
S45	PD-	L-	L-	H+	H-
S45	PD+	L+	L+	H-	H+
S270	PD-	H-	L-	H+	L-
S270	PD+	H+	L+	H-	L+
S135	PD-	L-	H-	H+	L-
S135	PD+	L+	H+	H-	L+

Even though it is not shown here, the repetition of the experiment on the same condition showed that the magnitude ratio is constant and independent of magnitude of PD current pulse. These results indicate that the ratio of magnitude of PD current flowing on each phase provides information of the particle position on the cross section of three phase construction.

5. Discussion

5.1 Electric field inside the three-phase construction and pd occurrences

The PDIV characteristics are discussed first. The results show that PDIV- is lower than PDIV+ for the particles on HV conductor and on the contrary for the particles on the tank. Although these results are natural phenomena, let us discuss these results since it is important to explain the dependence of phase of applied voltage at PD occurrence on the particle position. Positive PD is generated by an electron initiated by collision detachment of negative ions in high electric field region. Thus, positive PD generation depends on whether or not negative ions exist around the particle tip. The negative ions at positive PD inception phase can be derived from PD in the previous cycle and or cosmic rays. The high field region initiating PD is so restricted that, even under continuous three-phase AC voltage application, the generation of an initial electron would be necessary condition for PD initiation. On the other hand, negative PD is generated by an initial electron derived from the field emission from the electrode surface. Thus, the generation of an initial electron for negative PD depends only on the electric field strength on the electrode surface. Therefore, an initial electron can be generated more easily for negative PD than for positive PD.

In the case of the particle on S conductor, the polarity of particle tip is negative when the polarity of S voltage is negative. Therefore, the first PD occurs in the negative half cycle of S voltage. In the case of the particle is on the tank and face to S conductor, the polarity of the particle tip is negative when the polarity of S voltage is positive. Therefore, the first PD occurs in the positive half cycle of S voltage. Because the particle adhered on the tank needs higher voltage to attain the same level of electric field than particle adhered on the conductor, PDIV of particle on the tank is higher than PDIV of particle on HV conductor.

PDIV is determined by PDIV criterion which depends on effective ionization coefficient, α [17,18]. PDIV criterion is given by Schumann equation as follows.

$$\int_0^{x_c} \bar{\alpha}(x) dx = K \quad (1)$$

where $\bar{\alpha} = \alpha - \eta$. α is Townsend's first ionization coefficient and η is the attachment coefficient, and both are functions of the electric field, atmospheric pressure, and temperature. X is the distance from the highly electrode surface and the point near electrode surface where $\alpha = \eta$. It is sometimes called the critical avalanche length or the boundary of the corona layer. $K = 20$ for air at 1 atm [18].

PDIV therefore depends on the electric field on the tip and the field distribution along the axis of the particle since α is a function of the electric field intensity. For air [18]:

$$\alpha / p = 22 (E/p - 0.244)^2 \quad \text{for } 0.244 < E/p < 0.5 \quad (2)$$

where E is electric field intensity in kV/cm, while p is air pressure in kPa. Because the electric field on the particle tip is much higher than on the other part, PDIV is influenced mainly by the electric field on the particle tip.

Let's observe the electric field characteristics inside the three-phase construction. Figure 11 shows periodic change of absolute electric field on the particle tips during one cycle of S applied voltage at different positions (R315, S45, E270, and T0). The electric field on each particle tip was calculated at 1 kV applied voltage for the comparison convenience. The electric field calculation point is determined so that the electric field at the point at PDIV is equal to critical electric field E_{cr} in air at atmospheric pressure ($E_{cr} = 3$ kV/mm). The critical electric field is the field at which the ionization begin to take place if $\alpha = \eta$.

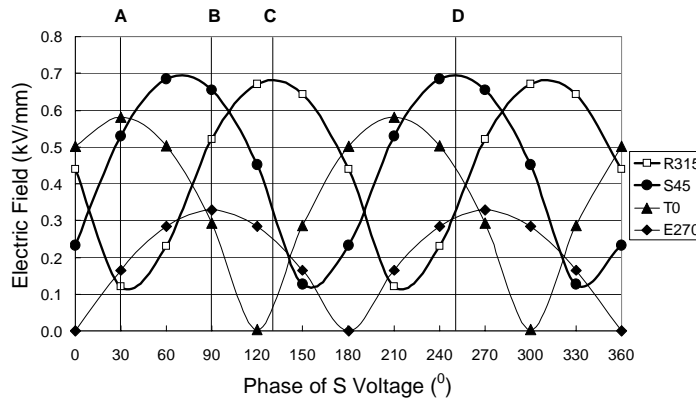

Figure 11. Periodic change of electric field on the particle tips

As shown in Figure 11 at certain position (x,y) inside the three phase construction the electric field is rotating with varying magnitude, i.e sinusoidal in two perpendicular directions without necessarily coinciding zero crossings. The electric field stress on each point inside the construction varies with the phase of the applied voltage. Every a half cycle the field achieves the minimum and the maximum values. Every a half cycle the pattern of the electric field stress is repetitive. It appears in Figure 11 that the value of the maximum electric field depends on

the particle position. It is reasonable because the gap distance and the electrode configuration of the three-phase construction depend on the particle position.

Figure 12 shows the maximum electric field on the particle tip of a particle on various positions at 1 kV applied voltage. It appears that the electric field of the particle on the conductor face to the other conductor (phase-phase region) is higher than that on the other place. Because PDIV depends on the electric field, these electric field calculations explain reasonably the experimental results: PDIV of particles with the same size depend on the particle position; and PDIV of the particles on the conductor facing to the other conductor is higher than that on the other place.

It is also shown in Figure 12 that the maximum electric field on the particle tip on different positions occurs at different phase of applied voltage. For example, the maximum electric field on the tip of S45 particle occurs at the phase of S voltage θ_S is 67° and 247° , while one of E270 particle occurs at $\theta_S = 90^\circ$ and $\theta_S = 270^\circ$. Because PD is initiated at the maximum electric field, these electric field characteristics result in the phase dependence of PD occurrence at PDIV on the particle position.

Figure 13 summarizes phase angle of S applied voltage at maximum electric field for a particle on the different position on R, S, and T conductors and on the tank. In general, PD of a particle on one phase conductor occurs on the peak of applied voltage at the related phase. The effects of the other phases take a place when the particle faces to another conductor, resulting in the shifting of the phase of maximum electric field and PDIV from the peak of applied voltage.

These calculation results explain the experimental results summarized on Figure 9. For example, negative PDIV of S45 particle occurred at $\theta_S = 247^\circ$, while negative PDIV of E270 particle occurred at $\theta_S = 90^\circ$. Note that negative PDIV is easier to occur than positive PDIV for a particle adhered on the conductor and on the contrary for a particle adhered on the tank.

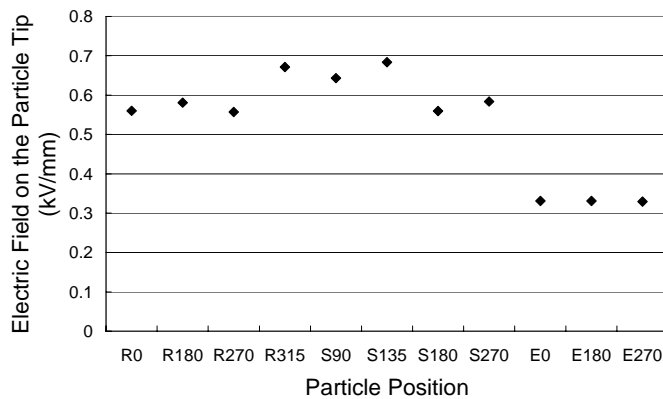

Figure 12. Electric field on the particle tip at 1 kV applied voltage

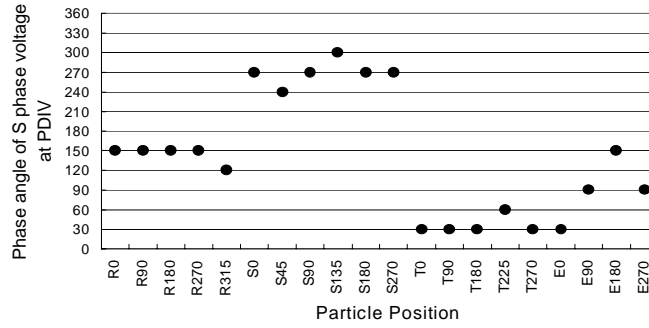

Figure 13. Phase of maximum electric field for a particle on the different position

5.2 Cross interference phenomena

The experimental results revealed that discharge from particle on one phase conductor caused currents to flow on the other phases, not only on the phase where the particle exists. The equivalent circuit of three-phase configuration with S90 particle and the measurement system are shown in Figure 14 to explain the phenomena. Partial discharge resulting from S90 particle is described as a pulse source. Insulation regions between the tank and each conductor and between conductors are described as their equivalent coupling capacitors; those are C_R , C_S , C_T and C_{RS} , C_{ST} and C_{RT} . By LCR meter, the capacitances are estimated to be $C_R=9.5$ pF, $C_S=7.9$ pF, $C_T=9.6$ pF, $C_{RS}=5.3$ pF, $C_{RT}=3.7$ pF, $C_{ST}=6.1$ pF.

Let us analyze the circuit. If negative discharge occurs in S90 particle, a small amount of charge is induced to R and T phase. A large amount of charge flow in S phase conductor to ground (path S). Since the current flows toward positive sign of CT_S , it is measured as positive current by CT_S . Then the current is divided into three directions: R conductor (path R), T conductor (path T), and the tank (path TANK). Since they flow toward negative sign of each CT, it is measured as negative current by CT_R , CT_T , and CT_{TANK} . The currents are transmitted from R and T conductor to tank, and then from tank to S phase conductor, because of the presence of coupling capacitances between the two conductors and between conductor and the tank. These discharge current path are depicted in Figure 14.

The discharge current flowing in each phase was estimated based on the equivalent circuit and dominant frequency of discharge current. The frequency was estimated based on the rise time of PD current waveforms measured for particles attached on different positions. Average rise time (t_r) of PD current was 17.5 ns so that the dominant frequency of PD current can be determined by the relation $f = 0.35/t_r$, giving $f = 20$ MHz.

If the current flowing in path S is I (high), the currents flowing in R, T, and tank paths are 0.46I (medium), 0.53I (medium), and 0.01I (low), respectively. These calculation results agree with the magnitude of discharge current resulting from the measurement in the term of magnitude level, although there are small differences in values.

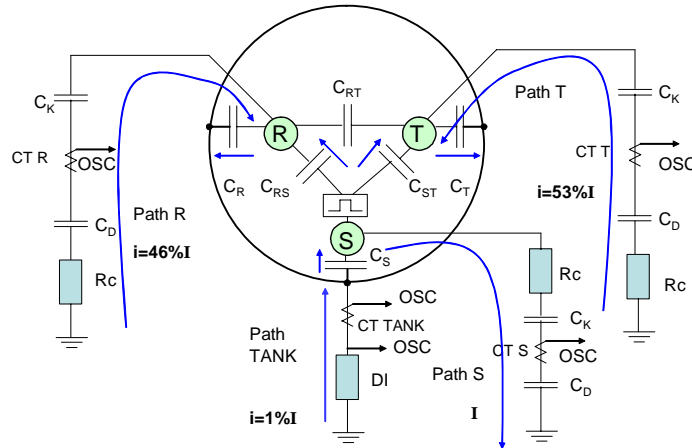

Figure 14. Equivalent circuit and path of PD current of S90 particle

6. Conclusions

PD characteristics in three-phase construction under three-phase voltage were investigated. The measurement system for observing discharge characteristics in three-phase construction was developed. PD from a particle on the different positions on the conductor and on the tank was observed. The conclusions are as follows.

1. Measuring PD signals only at the enclosure or on one of the phases of three phase construction will result in the position dependent sensitivity for partial discharges.
2. Partial discharge inception voltage of a particle adhered on different position differs depending on the particle position.
3. Phase where PD occurs at PDIV depends on particle position.
4. PD caused by a particle on one phase conductor is induced and detected on the other phase conductors.
5. Magnitude ratios of PD current flowing on each phase are unique for each particle on different positions. The ratio is constant and independent of magnitude of PD current pulse.
6. Polarity of PD current flowing on each phase depends on particle position.

Calibration and measurement results indicate that PD measurement on three phase construction must be conducted on three phases simultaneously to obtain measurement result of PD occurring in entire region with high sensitivity and to obtain information of the location of PD source. Experimental results indicate that phase of applied voltage at PDIV and magnitude ratio of discharge current flowing on each phase provides information of the particle position on the cross section of three phase construction. Therefore, they can be considered as parameters for estimation of particle position on the cross section of three phase equipment.

References

- [1] Umar Khayam, T. Ishitobi, S. Ohtsuka, S. Matsumoto, M. Hikita: "Effect of Elliptical Nature of Rotating Electric Field on Partial Discharge Pattern in a Three-phase Construction", *IEEJ Transaction on Fundamentals and Materials*, Vol. 127, No.9, 2007, pp. 524-530.

- [2] S. Yanabu, H. Okubo, S. Matsumoto, "Metallic Particle Motion in 3-Phase SF₆ Gas Insulated Bus", *IEEE Transactions on Power Delivery* Vol. PWRD-2, No. 1, January 1987.
- [3] Wielen, E.F. Steennis, and P.A.A.F Wouters, "Fundamental aspects of excitation and propagation of on-line PD signals in three phase medium voltage cable systems", *IEEE Trans. on DEI*, vol 10, no4, pp. 678-688, Aug. 2003.
- [4] S. Yanabu, Y Murayama, and S. Matsumoto, "SF₆ Insulation and its Application to HV Equipment", *IEEE Transactions on Electrical Insulation*, Vol. 26, No.3, pp 358-366, 1991.
- [5] G.V.N. Kumar, J.Amarnath, B.P. Singh, K.D. Srivastava, "Electric Field Effect on Metallic Particle Contamination in a Common Enclosure Gas Insulated Busduct", *IEEE Trans. on DEI*, Vol 14, No. 2, pp. 334-340, Apr. 2007.
- [6] Kreuger, F.H, Samir Shihab, "Partial Discharge Measurement on Three-core Belted Power Cables", *IEEE Transactions on Power Delivery*, Vol. 4, No. 2, April 1989
- [7] E. Harkink, F.H. Kreuger, P.H.F. Morshuis: "Partial Discharges in Three-core Belted Power Cables", *IEEE Transactions on Electrical Insulation*, Vol. 24, No. 4, pp. 591-598, Aug. 1989.
- [8] R. Heinrich, S. Schaper, W. Kalkner, R. Plath, A. Bethge, "Synchronous Three-phase PD Detection on Rotating Machines", *XIIIth ISH, Netherlands 2003*.
- [9] S.Schaper, W. Kalkner, R.Plath, H. Emanuel, "Synchronous Multi Terminal PD Detection on Power Transformer", *XIIIth ISH, Netherlands 2003*.
- [10] W. Kalkner, A. Obralic, M. Kaufhold, R. Plath, "Investigation of PD-Pulse Propagation and Coupling between Three-phases of a Stator of a Rotating Machine", *XIVth ISH, Paper B-44, China, 2005*.
- [11] W. Kalkner, A. Obralic, A. Bethge, R. Plath, "Synchronous 3-Phase Partial Discharge Detection on Rotating Machines", *XIVth ISH, Paper G-042, China, 2005*.
- [12] A.M. Jafari, A. Akbari, "Multi-Source Partial Discharge Diagnosis in Three-phase High Voltage Devices", *XIVth ISH, Paper G-051, China, 2005*.
- [13] Ronald Plath, "Multi-channel PD Measurement", *XIVth ISH, Paper J-04, China, 2005*.
- [14] Akbari, A.M. Jafari, M. Kharezi, "Partial Discharge Localisation in Power Transformers with Delta Connected Windings", *XIVth ISH, Paper G-052, China, 2005*.
- [15] A.M. Jafari, A. Akbari, "Multi-Source Partial Discharge Diagnosis in Three-phase High Voltage Devices", *XIVth ISH, Paper G-051, China, 2005*.
- [16] Ronald Plath, "Multi-channel PD Measurement", *XIVth ISH, Paper J-04, China, 2005*.
- [17] D.B. Philips, R.G. Olsen, P.D. Pedrow, "Corona Onset as a Design Optimization Criterion for High Voltage Hardware", *IEEE Transaction on Dielectrics and Electrical Insulation* Vol. 7 No. 6 pp. 744-751, December 2000.
- [18] N.H. Malik and A.H. Qureshi, "Calculation of Discharge Inception Voltage in SF₆-N₂ Mixtures", *IEEE Transaction on Electrical Insulation* Vol. EI-14 No.2 pp. 70-76, 1979.

Umar Khayam was born in Indonesia in 1975. He received B.Eng. with honor (cum laude) and M.Eng. degrees in electrical engineering from Institut Teknologi Bandung (ITB), Indonesia, in 1998 and 2000, respectively. He worked as a researcher and lecturer assistant at High Voltage and High Current Engineering Laboratory, ITB, from 1999 to 2004. He received Doctor Degree in Electrical Engineering from Kyushu Institute of Technology (KIT), Japan in 2008. He was a researcher at Hikita Laboratory, KIT, Japan, during 2008-2009. Since 2008, he is a Lecturer at School of Electrical Engineering and Informatics ITB, Indonesia. His research interests include the partial discharge measurement and phenomena in electric power apparatus. He is a member of IEEJ since 2005. Dr. Umar Khayam can be contacted at School of Electrical Engineering and Informatics ITB, Jl. Ganesha 10 Bandung, Indonesia 40132 or at umar@hv.ee.itb.ac.id.



Shinya Ohtsuka was born in 1971. He received his B. S. and M. S. degrees from Kyushu University, Japan, in 1994, 1996, respectively. He finished his Doctor Course of the Dept. of Electrical and Electronic Systems Engineering at Kyushu University in 1998. He was a research fellow (DC1) of the Japan Society for the Promotion of Science (JSPS) from 1996 to 1998, then became a JSPS Research Fellow (PD) in 1999. Since 1999, he has been an Assistant Professor at Kyushu Institute of Technology, Japan and promoted to Associate Professor at the same university in 2006. His research interests include the insulation properties of environmentally-benign gas as SF₆ substitute, PD detection technique for insulation diagnosis of power apparatus and the superconductivity engineering. He has a Doctor Degree of Engineering. Dr. Ohtsuka is a member of the IEEJ, the IEEDJ and the Cryogenic Society of Japan.



Satoshi Matsumoto (Member) was born in 1955. He received the Ph.D in 1984 in electrical engineering from the University of Tokyo, and joined Toshiba Corporation. He was visiting Professor at Kyushu Institute of Technology from 2003-2006. He is presently visiting Professor at Shibaura Institute of Technology. He is a member of the IEEJ, and Senior Member of IEEE.



Masayuki Hikita (M'96-SM'00) was born in 1953. He received B. S., M. S. and Dr. degrees in electrical engineering from Nagoya University of Japan, in 1977, 1979, and 1982, respectively. He was an Assistant, a Lecturer, an Associate Professor at Nagoya University in 1982, 1989, and 1992, respectively. Since 1996, he has been a professor of the Department of Electrical Engineering, Kyushu Institute of Technology. He was a Visit Scientist at the High Voltage Laboratory in MIT, USA, from August 1985 to July 1987. Dr. Hikita has recently been interested in research on development of diagnostic technique of electric power equipment. He is a member of the Japan Society of Applied Physics and the IEEJ. He is now a senior member of the IEEE.

